

XL1 PARTS LIST

Note: Only stocked parts are listed.

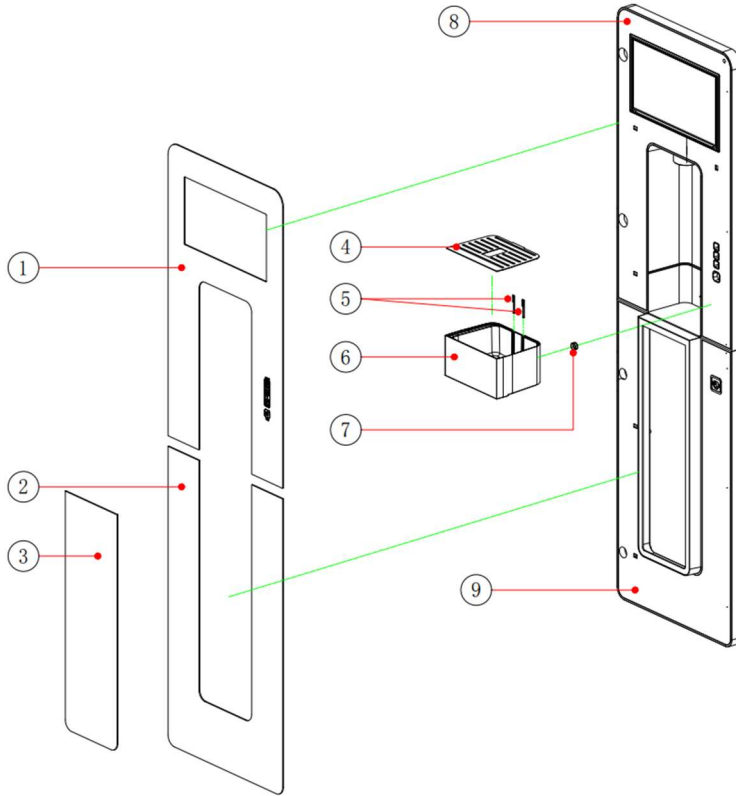

No.	Description	Part #
4+6	Drip Tray Assy (v1 Bottom Drain)	AB156A01
4+6	Drip Tray Assy (v2 Back Drain)	AB156B01
9	Lower Front Panel Assy	AB155A01

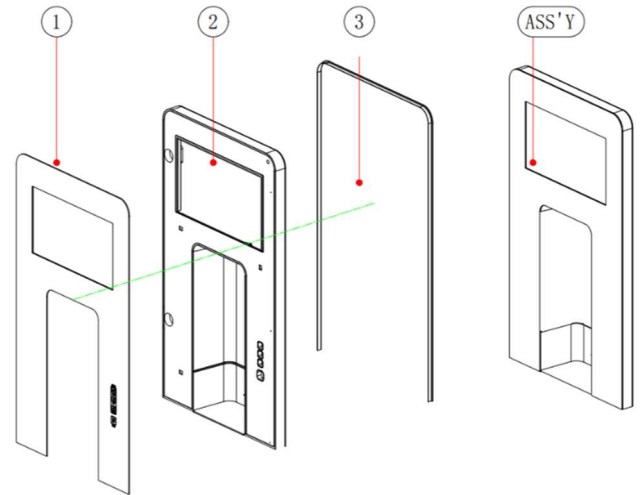

No.	Description	Part #
ASSY	Upper Front Panel Assy (v1 Bottom Drain)	AB154A01
ASSY	Upper Front Panel Assy (v2 Back Drain)	AB154B01

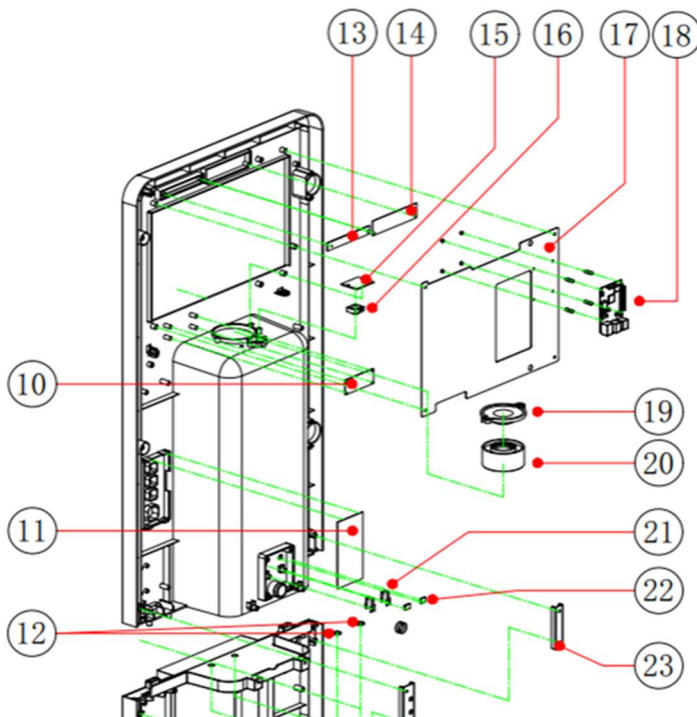

No.	Description	Part #
10	LCD Touch PCB	EB164A01
11	Touch PCB	EB162A01
14	LVDS Converter PCB	EB166A01
15	Dispense LED PCB	EB157A01
18	Raspberry Pi PCB	EB159A01
20	Dispense Cover	PK196A01

No.	Description	Part #
26	Side Panel - Left	IB204A01
28	SMPS	EG048A01
29	Main PCB	EB158A01
30	Door Hinge	IJ001A01
32	3-Way Dispense SV	EC033A01
35	Hot Tank	TB023A01
44	Top Lid	PA034A01
65	Caster	IJ003A01
80	Rear Panel	IB210A01
85	Cold Water Pump	EE023A01
89	XL1 Booster Pump	EE012A01
95	Side Panel - Right	IB205A01
Not Shown	TDS Sensor	EJ033A01

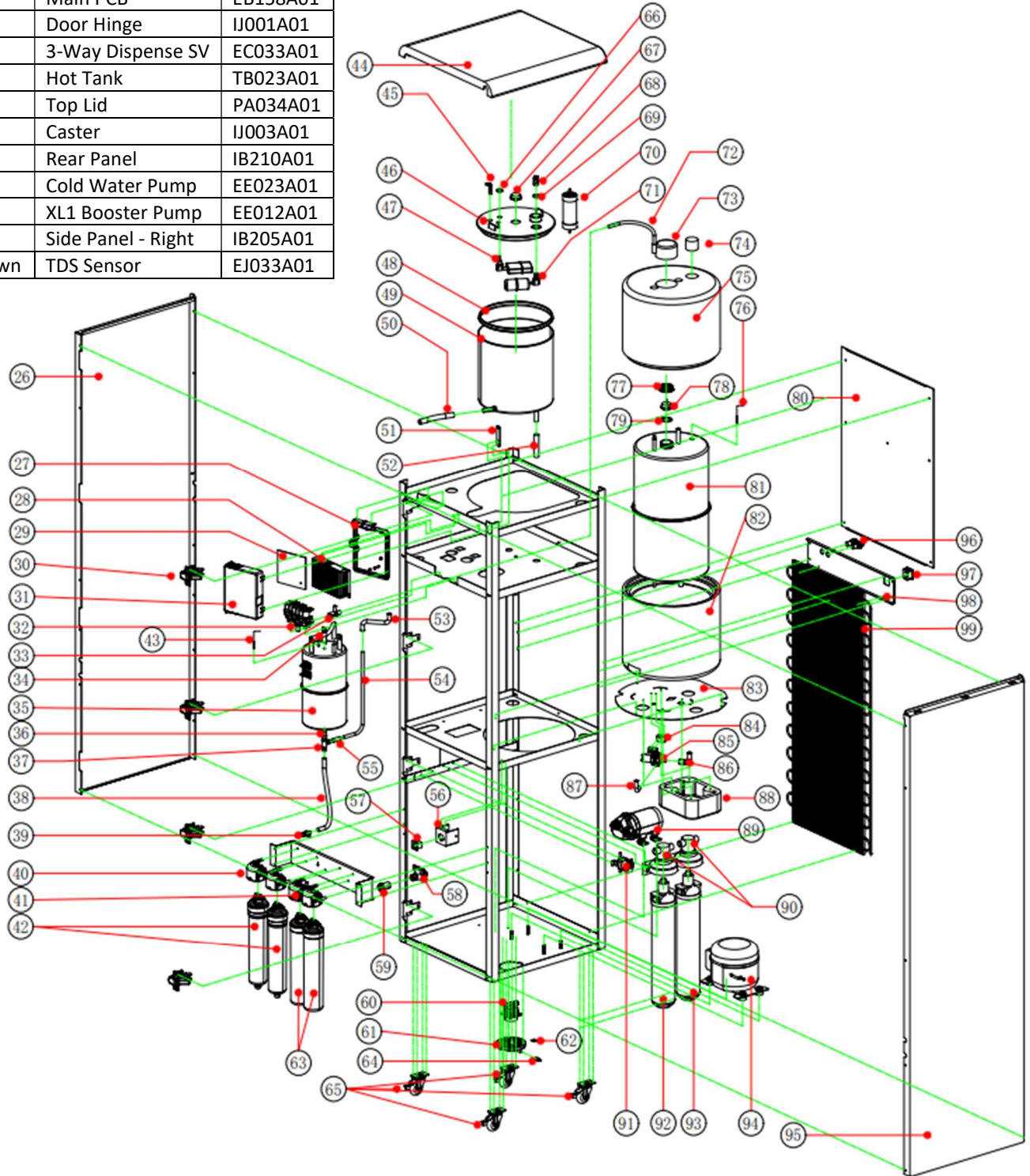

XL1 ELECTRICAL DIAGRAM

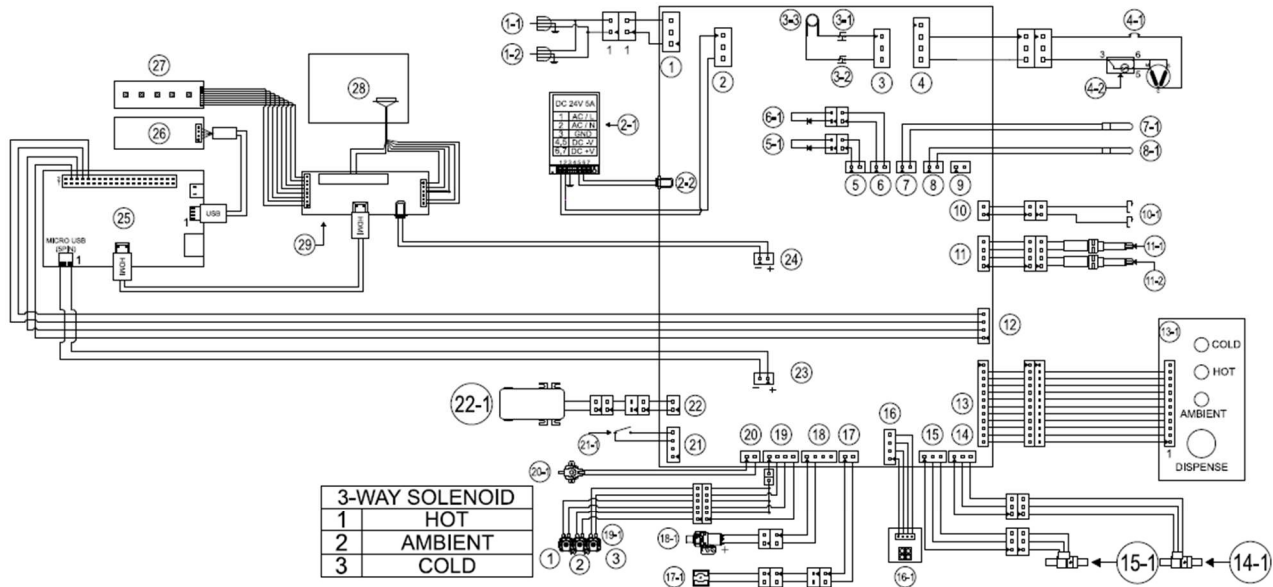

No.	PART No.	PART NAME.	No.	PART No.	PART NAME.	No.	PART No.	PART NAME.
1	CN 1	AC IN	8	CN 20	HOT-TH	18	CN 9	WATER PUMP
1-1	-	POWER INPUT (AC 120V / 60Hz)	8-1	-	HOT SENSOR	18-1	-	WATER PUMP (COLD)
1-2	-	DRAIN POWER INPUT	9	CN 19	AMBIENT -TH	19	CN 8	DISPENSE S/V
2	CN 24	SMPS IN	10	CN 18	TRAY SENSOR	19-1	-	3-WAY SOLENOID VALVE
2-1	-	SMPS (DC 24V / 5A)	10-1	-	TRAY SENSOR BRACKET	20	CN 7	RO S/V
2-2	-	DC 24V ADAPTOR	11	CN 17	TDS SENSOR	20-1	-	RO SOLENOID VALVE
3	CN 3	HEATER	11-1	-	TDS IN	21	CN 6	MICRO S/W
3-1	-	BIMETAL AUTO 95	11-2	-	TDS OUT	21-1	-	MICRO SWITCH
3-2	-	BIMETAL MANUAL 105	12	CN 16	RASPBERRY PI	22	CN 5	BOOST PUMP
3-3	-	HOT TANK (120V 500W)	13	CN14	TOUCH DISPLAY	22-1	-	BOOST PUMP
4	CN 12	COMPRESSOR	13-1	-	TOUCH PCB	23	CN 15	RASPBERRY PI POWER
4-1	-	OLP	14	CN 13	FLOW SENSOR 2 (RO DRAIN)	24	CN 4	LCD POWER
4-2	-	PTC	14-1	-	FLOW SENSOR (RO DRAIN)	25	-	RASPBERRY PI PCB
5	CN 23	UV LED (RESERVE TANK)	15	CN 12	FLOW SENSOR 1 (RO INLET)	26	-	LCD TOUCH PCB
5-1	-	UV LED (RESERVE TANK)	15-1	-	FLOW SENSOR (RO INLET)	27	-	LCD CONTROLLER PCB
6	CN 22	UV LED (COLD TANK)	16	CN 11	DISPENSE LED	28	-	LCD PCB
6-1	-	UV LED (COLD TANK)	16-1	-	DISPENSE LED PCB	29	-	LVDS CONVERTER PCB
7	CN 21	COLD-TH	17	CN 10	LEAK SENSOR			
7-1	-	COLD SENSOR	17-1	-	LEAK SENSOR PCB			

XL1 CONSTRUCTION

